

Contents

Part 1 - Overview	1
▶ Specs Overview	1.1
▶ Dimensions	1.2
▶ Package	1.3
▶ Layout	1.4
Part 2 - Flight Controller	2
▶ Peripheral Connection	2.1
▶ Installation Orientations	2.2
▶ App Connection	2.3
Part 3 - ESC	3
▶ Connecting Motors and Power Wires	3.1
Part 4 - Firmware Flashing	4
▶ Flight Controller Firmware Flashing	4.1
▶ ESC Firmware Flashing	4.2
Part 5 - Specifications	5
▶ Specifications	5.1

Part 1 - Overview

► Specs Overview

1.1

Product Name	SpeedyBee F405 AIO
Bluetooth Tuning	Supported
Firmware Update via App	Supported
Power Input	3-6S
Mounting	25.5x25.5mm
Dimensions	33.0mm (L) x 33.0mm (W) x 8mm (H)
Weight	13.6g (with CNC)

1.2

Dimensions ◀

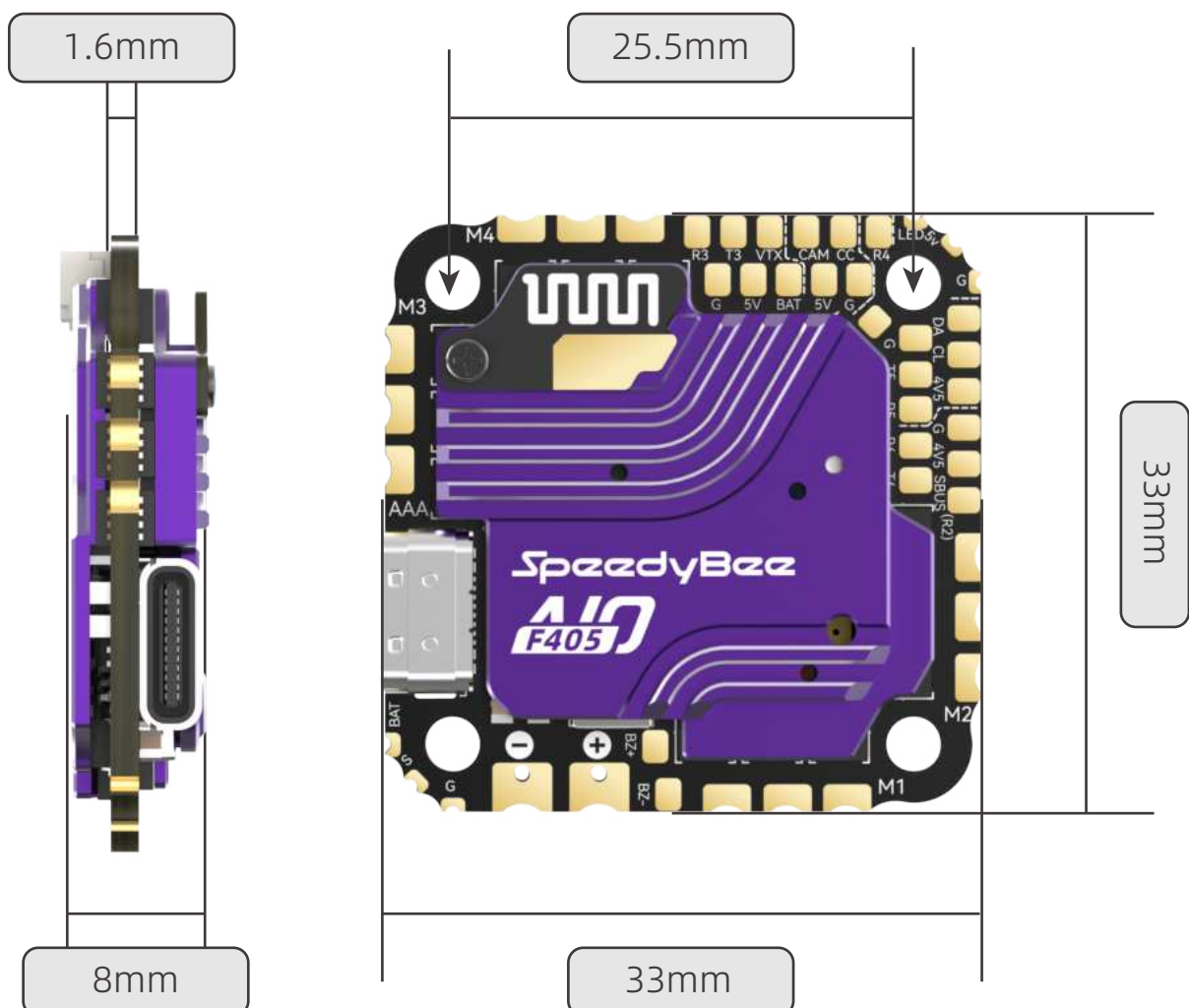



SpeedyBee F405 AIO x 1



Soldering Practice Board x 1



DJI Air Unit 6pin*80mm
Connection Cable x 1



35V 470uF
Electrolytic Capacitor x 1



M2 * 6.6mm Silicone
Dampening Sleeves x4



M2 Silicone Dampening Ring x 5



M2 Nylon Hex Nut x 5



XT30 Power Cable
(Length: 7cm)x 1

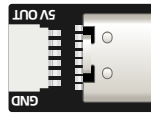

Type-C Extension Module x 1



Power Expansion Board x 1

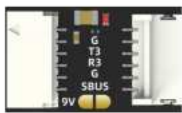

BEC x 1



Black Heat Shrink Tube for
Type-C Extension Module x 1



4-pin * 80mm Cable for Type-C
Extension Module x1



User Manual x 1



M2*20mm Screws for F405 AIO
& VTX Installation x 4



M2*12mm Screws for
F405 AIO Installation x4



Transparent Heat Shrink Tube
for External BEC x 1



6-pin * 30mm Cable for
External BEC x1



Capacitor Heat Shrink Tube x 2

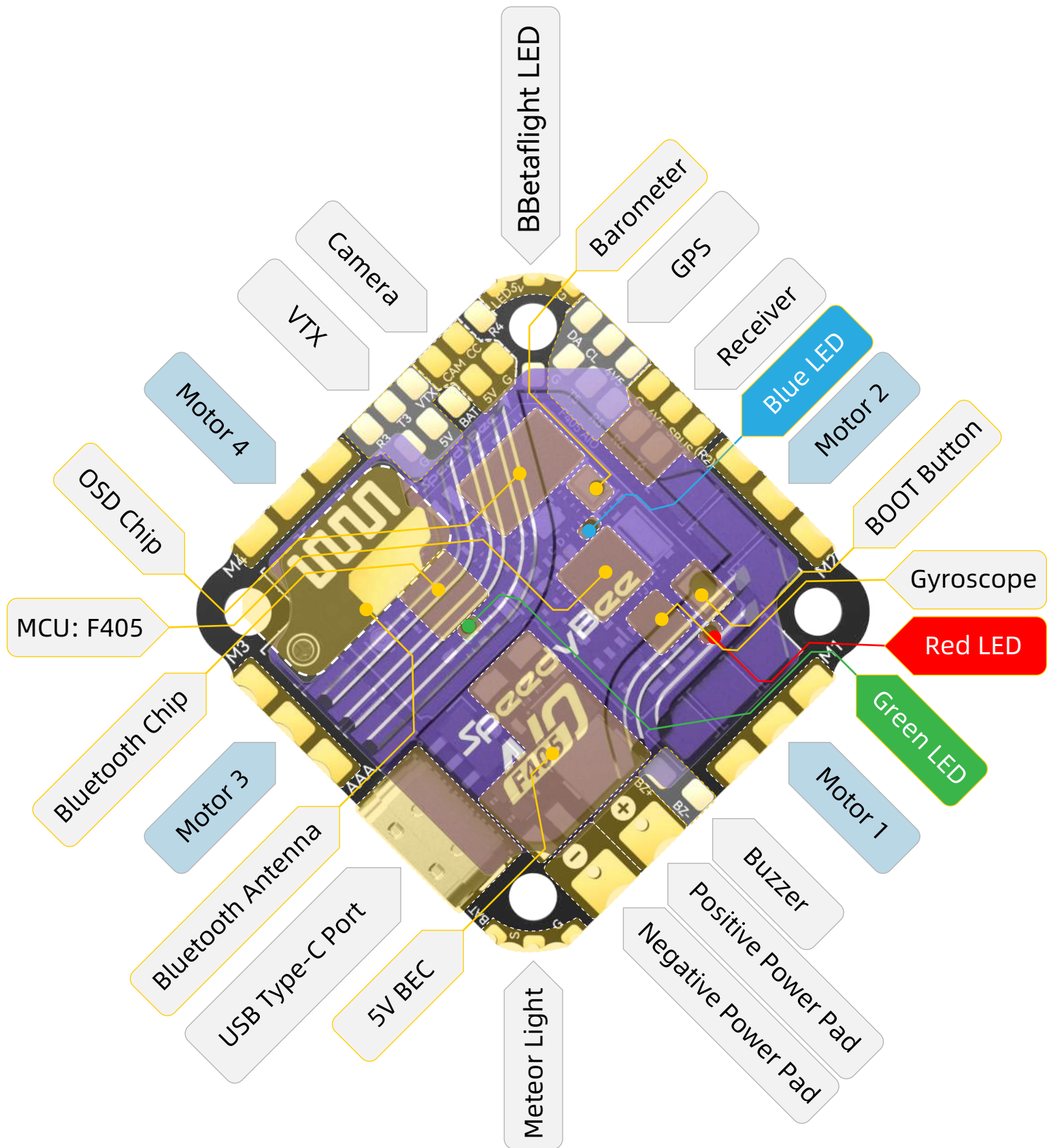

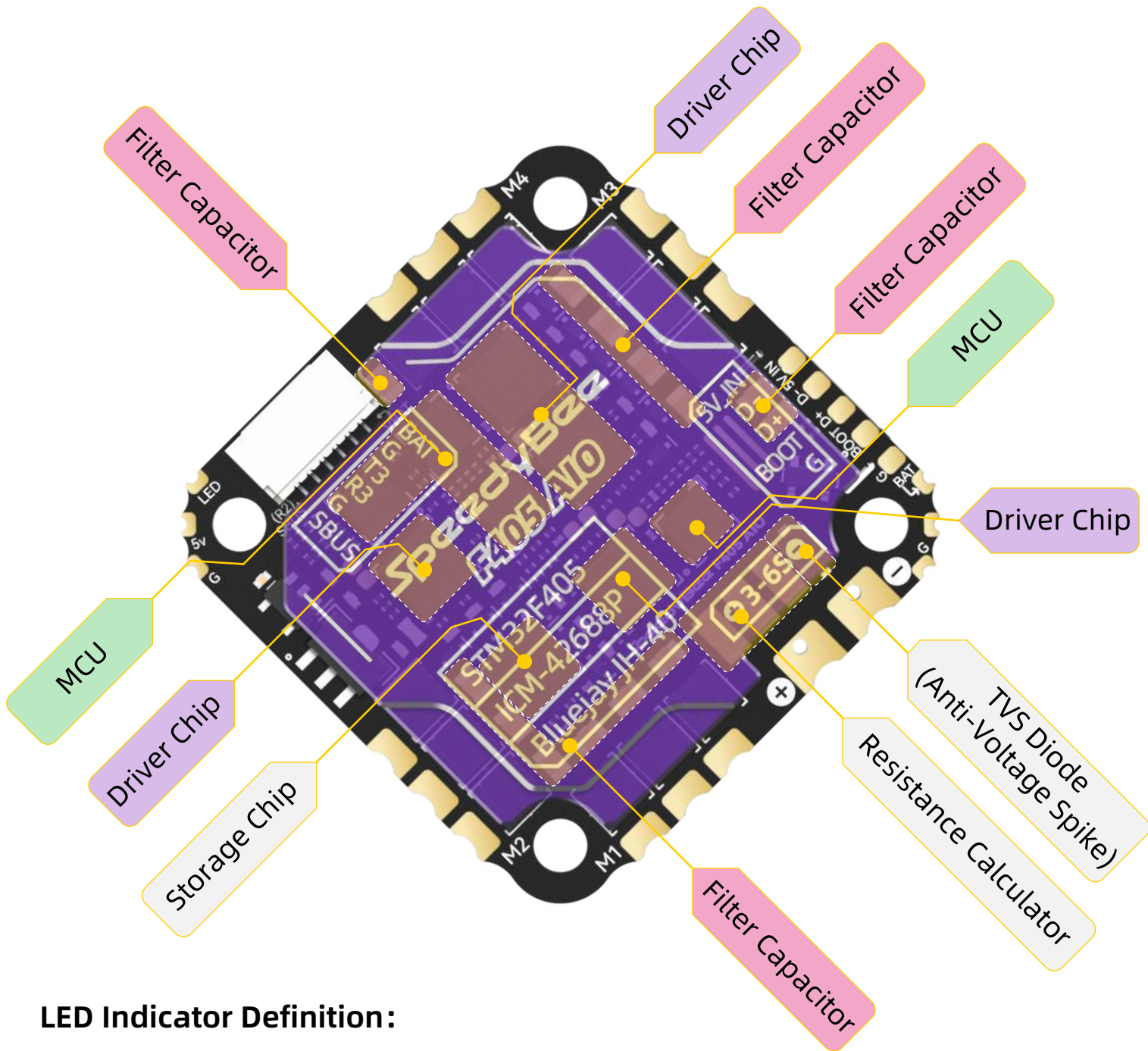

LED Indicator Definition:

Red LED - Flight controller power indicator. Solid Red after powering up.

Green LED - Bluetooth status indicator. Solid Green indicates Bluetooth is connected.

Blue LED - Flight controller status indicator, controlled by the flight controller firmware.

BOOT Button:

If the flight controller gets bricked and can't power up, please follow these steps to re-flash firmware for it:

- ① Hold the BOOT button (the only button on the flight controller) and power it on. The flight controller will enter DFU mode.
- ② Open the SpeedyBee App, go to the firmware flashing page, and follow the prompts to re-flash the firmware.

When the Meteor Light pad is connected to an LED strip, long press the BOOT button to toggle the LED strip on/off. When the LED strip is on, short press the BOOT button to switch LED colors.

Part 2 - Flight Controller

► Peripheral Connection

2.1

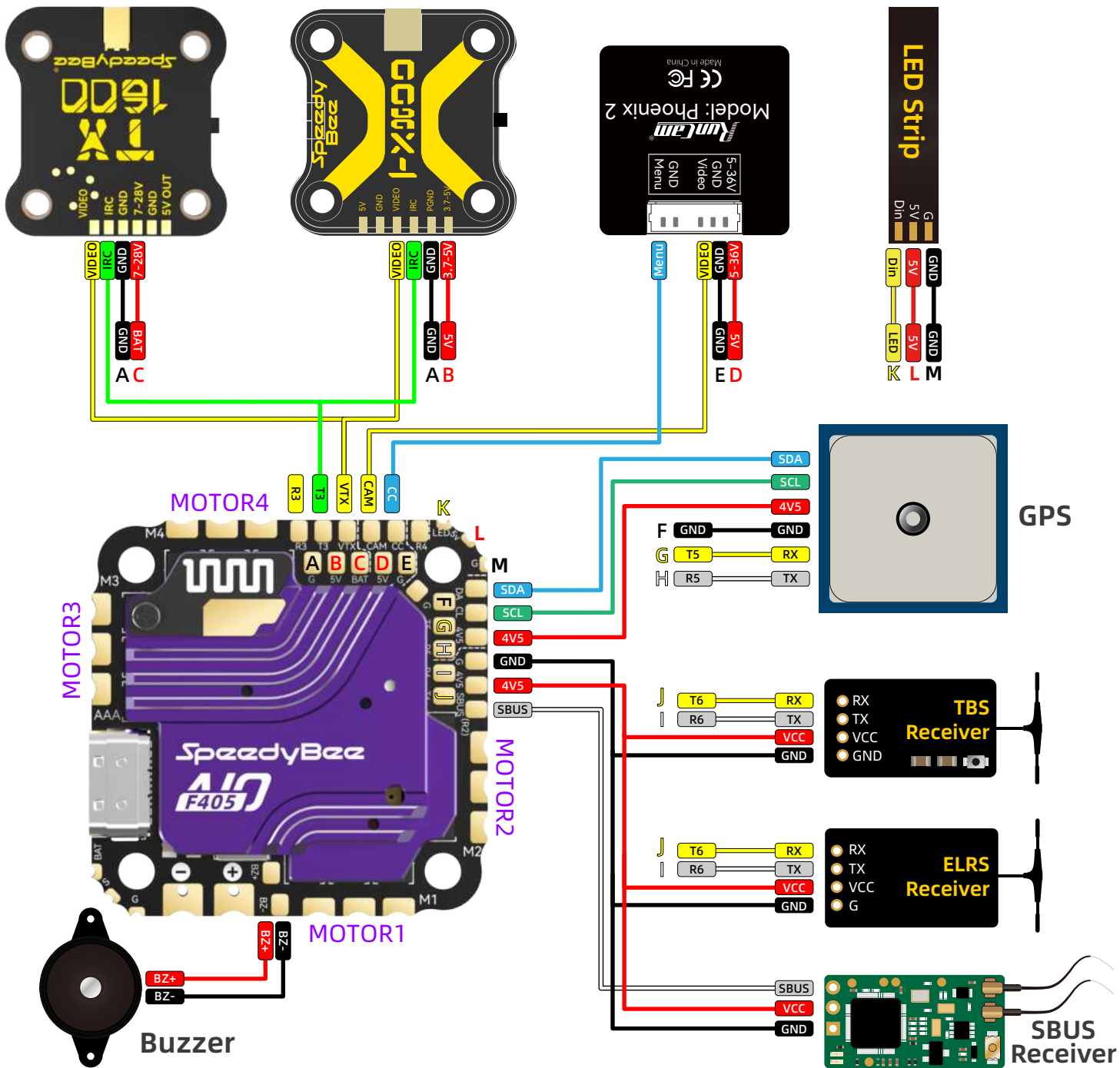

Included Accessories: Soldering Practice Board and External 5/9V BEC

Soldering Practice Board

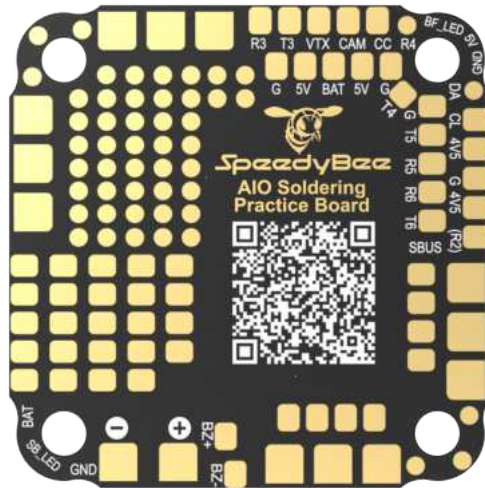

The included soldering practice board has the same pad layout as the F405 AIO. It is recommended to scan the QR code to watch the soldering tutorial and practice on the board before performing the actual soldering.

External BEC

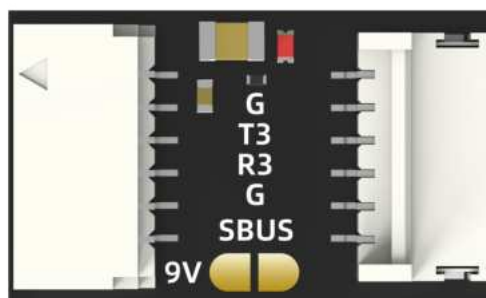

Default Output: 5V

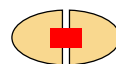

Optional output: 9V

The external BEC can be used to power peripherals such as a 9V VTX or 5V Meteor LED strips. By default, it outputs 5V, and by short-circuiting the two pads, it will output 9V.

TBS Receiver Connection and Settings:

Identifier	Configuration/MSP	Serial Rx	Telemetry Output	Sensor Input	Peripherals
USB VCP	<input checked="" type="checkbox"/> 115200 ▾	<input type="checkbox"/>	Disabled ▾ AUTO ▾	Disabled ▾ AUTO ▾	Disabled ▾ AUTO ▾
UART1	<input checked="" type="checkbox"/> 115200 ▾	<input type="checkbox"/>	Disabled ▾ AUTO ▾	Disabled ▾ AUTO ▾	Disabled ▾ AUTO ▾
UART2	<input type="checkbox"/> 115200 ▾	<input type="checkbox"/>	Disabled ▾ AUTO ▾	Disabled ▾ AUTO ▾	Disabled ▾ AUTO ▾
UART3	<input type="checkbox"/> 115200 ▾	<input type="checkbox"/>	Disabled ▾ AUTO ▾	Disabled ▾ AUTO ▾	Disabled ▾ AUTO ▾
UART4	<input type="checkbox"/> 115200 ▾	<input type="checkbox"/>	Disabled ▾ AUTO ▾	Disabled ▾ AUTO ▾	Disabled ▾ AUTO ▾
UART5	<input type="checkbox"/> 115200 ▾	<input type="checkbox"/>	Disabled ▾ AUTO ▾	Disabled ▾ AUTO ▾	Disabled ▾ AUTO ▾
UART6	<input type="checkbox"/> 115200 ▾	<input checked="" type="checkbox"/>	Disabled ▾ AUTO ▾	Disabled ▾ AUTO ▾	Disabled ▾ AUTO ▾

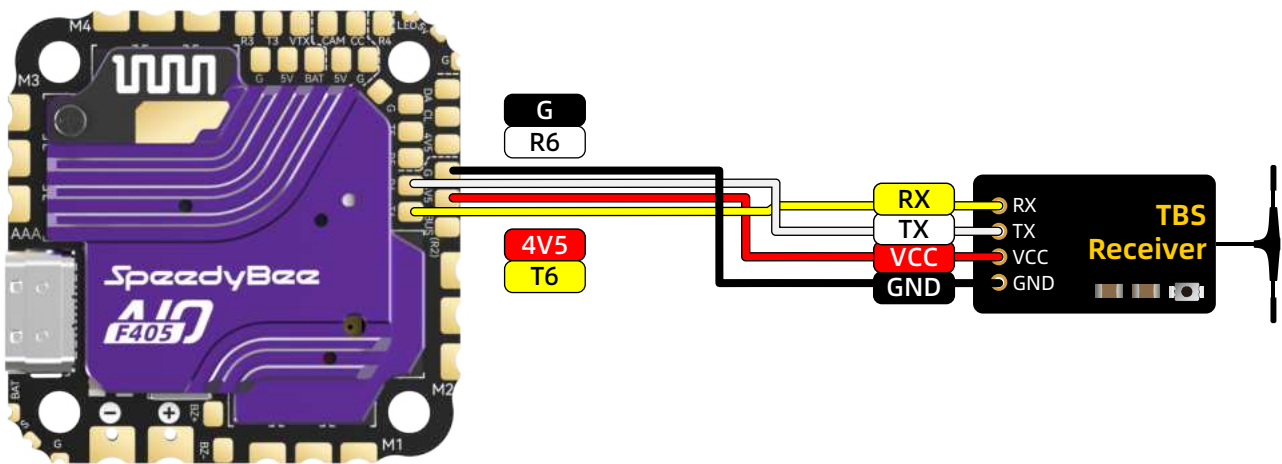

Setting Steps

1. Enable the UART6 serial receiver port on the Ports tab.
2. Set the receiver protocol to CRSF on the Receiver tab.

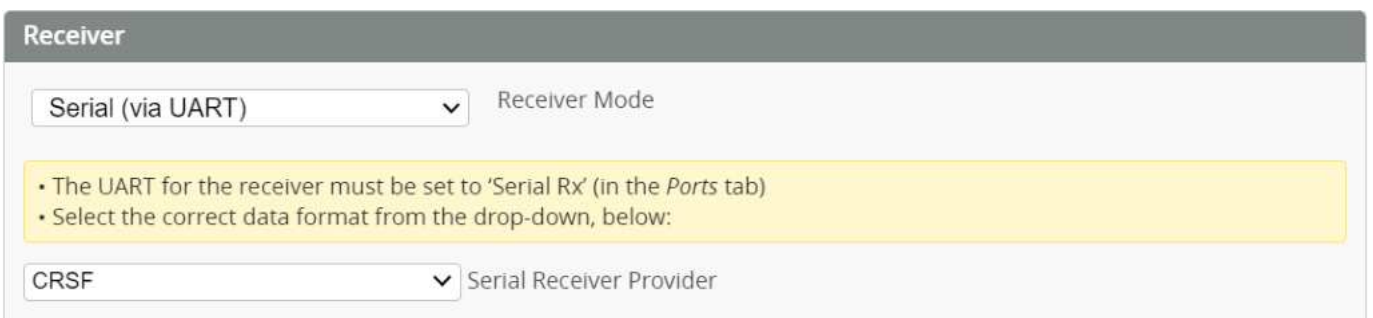

ELRS Receiver Connection and Settings:

Identifier	Configuration/MSP	Serial Rx	Telemetry Output	Sensor Input	Peripherals
USB VCP	<input checked="" type="checkbox"/> 115200 ▾	<input type="checkbox"/>	Disabled ▾ AUTO ▾	Disabled ▾ AUTO ▾	Disabled ▾ AUTO ▾
UART1	<input checked="" type="checkbox"/> 115200 ▾	<input type="checkbox"/>	Disabled ▾ AUTO ▾	Disabled ▾ AUTO ▾	Disabled ▾ AUTO ▾
UART2	<input type="checkbox"/> 115200 ▾	<input type="checkbox"/>	Disabled ▾ AUTO ▾	Disabled ▾ AUTO ▾	Disabled ▾ AUTO ▾
UART3	<input type="checkbox"/> 115200 ▾	<input type="checkbox"/>	Disabled ▾ AUTO ▾	Disabled ▾ AUTO ▾	Disabled ▾ AUTO ▾
UART4	<input type="checkbox"/> 115200 ▾	<input type="checkbox"/>	Disabled ▾ AUTO ▾	Disabled ▾ AUTO ▾	Disabled ▾ AUTO ▾
UART5	<input type="checkbox"/> 115200 ▾	<input type="checkbox"/>	Disabled ▾ AUTO ▾	Disabled ▾ AUTO ▾	Disabled ▾ AUTO ▾
UART6	<input type="checkbox"/> 115200 ▾	<input checked="" type="checkbox"/>	Disabled ▾ AUTO ▾	Disabled ▾ AUTO ▾	Disabled ▾ AUTO ▾

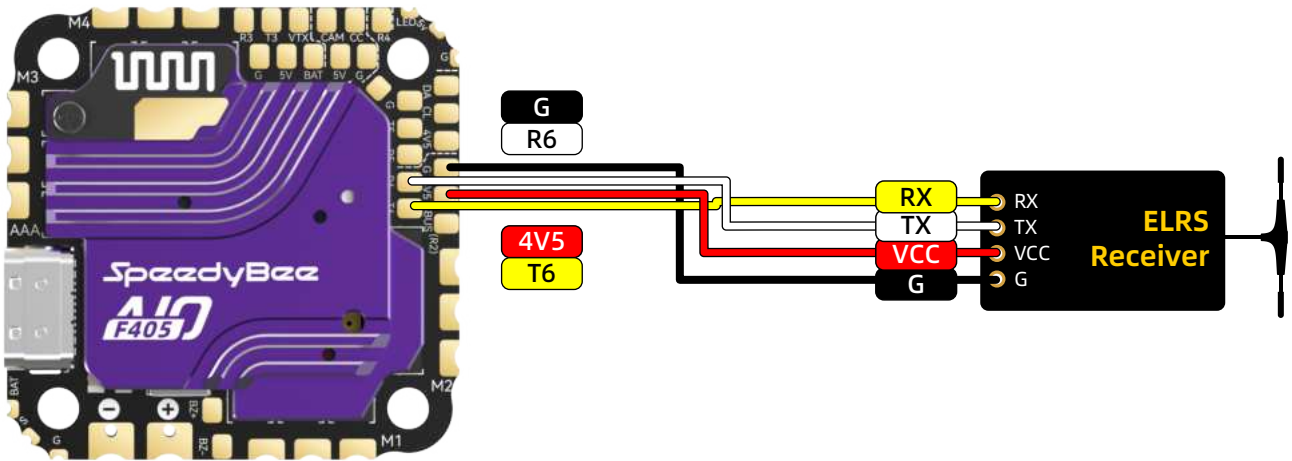

Setting Steps

1. Enable the UART6 serial receiver port on the Ports tab.
2. Set the receiver protocol to CRSF on the Receiver tab.

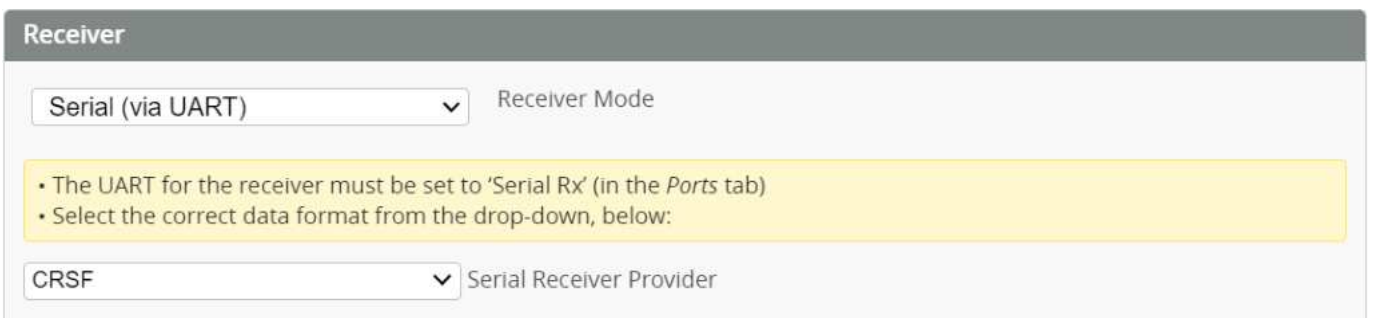

SBUS Receiver Connection and Settings:

Identifier	Configuration/MSP	Serial Rx	Telemetry Output	Sensor Input	Peripherals
USB VCP	<input checked="" type="checkbox"/> 115200 ▾	<input type="checkbox"/>	Disabled ▾ AUTO ▾	Disabled ▾ AUTO ▾	Disabled ▾ AUTO ▾
UART1	<input checked="" type="checkbox"/> 115200 ▾	<input type="checkbox"/>	Disabled ▾ AUTO ▾	Disabled ▾ AUTO ▾	Disabled ▾ AUTO ▾
UART2	<input type="checkbox"/> 115200 ▾	<input checked="" type="checkbox"/>	Disabled ▾ AUTO ▾	Disabled ▾ AUTO ▾	Disabled ▾ AUTO ▾
UART3	<input type="checkbox"/> 115200 ▾	<input type="checkbox"/>	Disabled ▾ AUTO ▾	Disabled ▾ AUTO ▾	Disabled ▾ AUTO ▾
UART4	<input type="checkbox"/> 115200 ▾	<input type="checkbox"/>	Disabled ▾ AUTO ▾	Disabled ▾ AUTO ▾	Disabled ▾ AUTO ▾
UART5	<input type="checkbox"/> 115200 ▾	<input type="checkbox"/>	Disabled ▾ AUTO ▾	Disabled ▾ AUTO ▾	Disabled ▾ AUTO ▾
UART6	<input type="checkbox"/> 115200 ▾	<input type="checkbox"/>	Disabled ▾ AUTO ▾	Disabled ▾ AUTO ▾	Disabled ▾ AUTO ▾

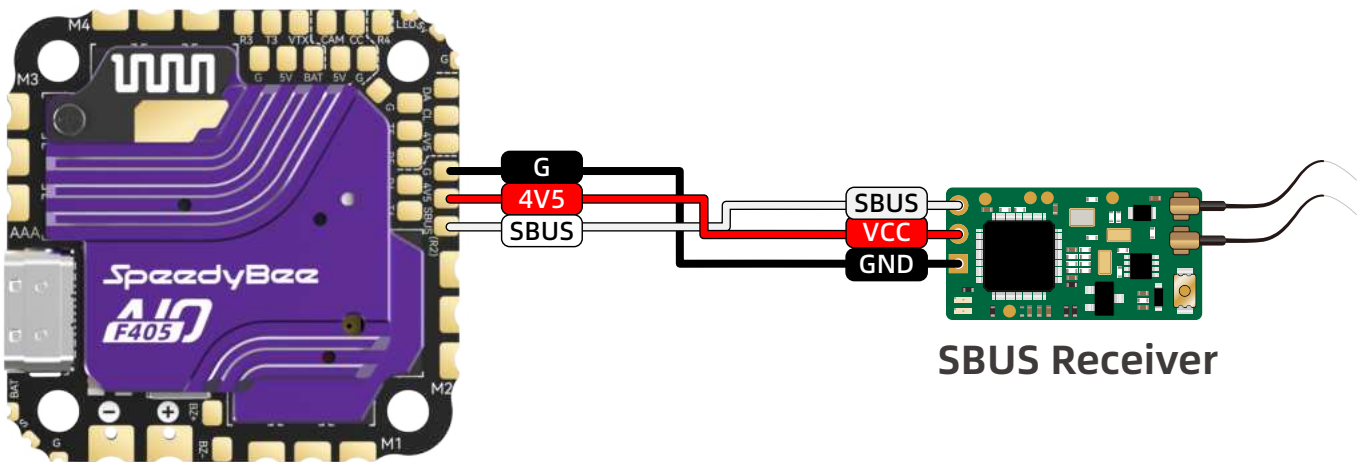

Setting Steps

1. Enable the UART2 serial receiver port on the Ports tab.
2. Set the receiver protocol to SBUS on the Receiver tab.



Spektrum SRXL2 Receiver Connection and Settings:

Identifier	Configuration/MSP	Serial Rx	Telemetry Output		Sensor Input		Peripherals	
USB VCP	<input checked="" type="checkbox"/> 115200 ▾	<input type="checkbox"/>	Disabled ▾	AUTO ▾	Disabled ▾	AUTO ▾	Disabled ▾	AUTO ▾
UART1	<input checked="" type="checkbox"/> 115200 ▾	<input type="checkbox"/>	Disabled ▾	AUTO ▾	Disabled ▾	AUTO ▾	Disabled ▾	AUTO ▾
UART2	<input type="checkbox"/> 115200 ▾	<input type="checkbox"/>	Disabled ▾	AUTO ▾	Disabled ▾	AUTO ▾	Disabled ▾	AUTO ▾
UART3	<input type="checkbox"/> 115200 ▾	<input type="checkbox"/>	Disabled ▾	AUTO ▾	Disabled ▾	AUTO ▾	Disabled ▾	AUTO ▾
UART4	<input type="checkbox"/> 115200 ▾	<input type="checkbox"/>	Disabled ▾	AUTO ▾	Disabled ▾	AUTO ▾	Disabled ▾	AUTO ▾
UART5	<input type="checkbox"/> 115200 ▾	<input type="checkbox"/>	Disabled ▾	AUTO ▾	Disabled ▾	AUTO ▾	Disabled ▾	AUTO ▾
UART6	<input type="checkbox"/> 115200 ▾	<input checked="" type="checkbox"/>	Disabled ▾	AUTO ▾	Disabled ▾	AUTO ▾	Disabled ▾	AUTO ▾

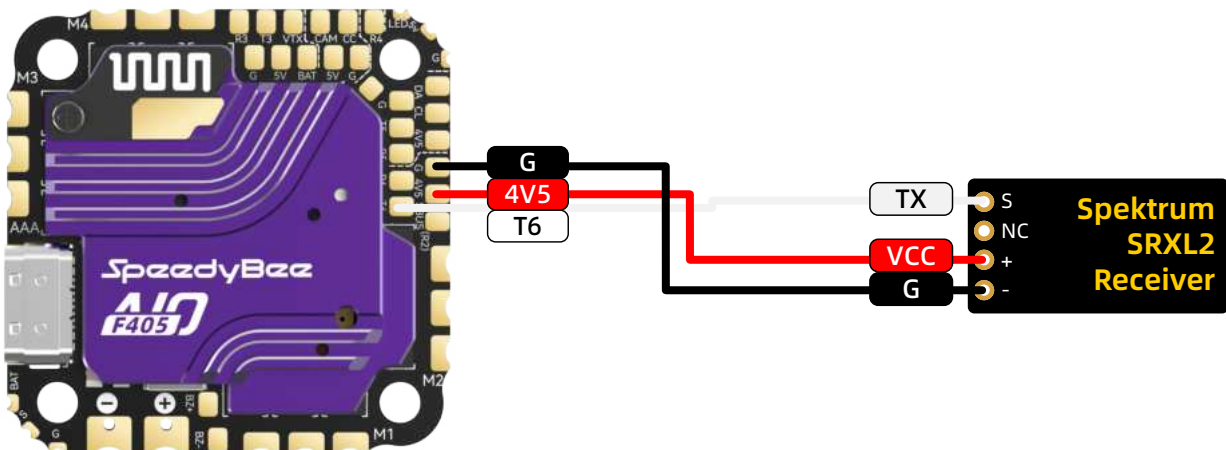

Setting Steps

1. Enable the UART6 serial receiver port on the Ports tab.
2. Set the receiver protocol to SPEKTRUM SRXL2 on the Receiver tab.

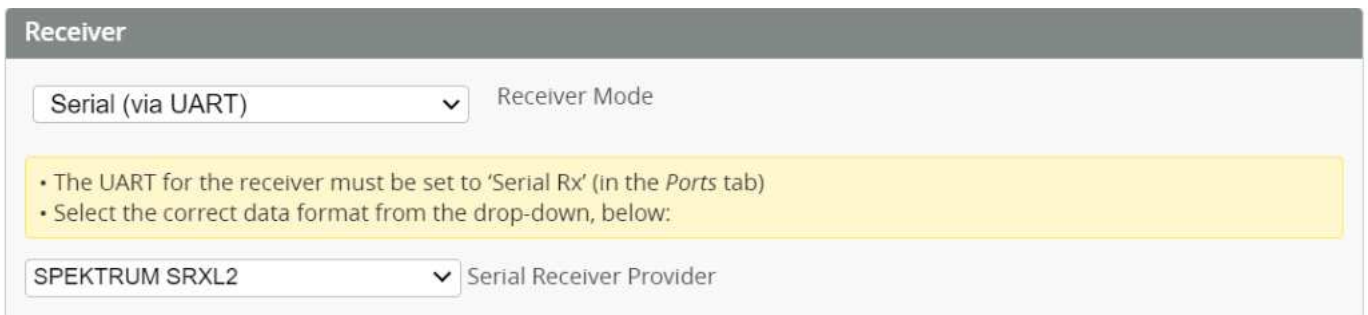

HD VTX Connection and Settings:

Identifier	Configuration/MSP	Serial Rx	Telemetry Output	Sensor Input	Peripherals
USB VCP	<input checked="" type="checkbox"/> 115200 ▾	<input type="checkbox"/>	Disabled ▾ AUTO ▾	Disabled ▾ AUTO ▾	Disabled ▾ AUTO ▾
UART1	<input checked="" type="checkbox"/> 115200 ▾	<input type="checkbox"/>	Disabled ▾ AUTO ▾	Disabled ▾ AUTO ▾	Disabled ▾ AUTO ▾
UART2	<input type="checkbox"/> 115200 ▾	<input checked="" type="checkbox"/>	Disabled ▾ AUTO ▾	Disabled ▾ AUTO ▾	Disabled ▾ AUTO ▾
UART3	<input checked="" type="checkbox"/> 115200 ▾	<input type="checkbox"/>	Disabled ▾ AUTO ▾	Disabled ▾ AUTO ▾	VTX(MSP+D ▾ AUTO ▾
UART4	<input type="checkbox"/> 115200 ▾	<input type="checkbox"/>	Disabled ▾ AUTO ▾	Disabled ▾ AUTO ▾	Disabled ▾ AUTO ▾
UART5	<input type="checkbox"/> 115200 ▾	<input type="checkbox"/>	Disabled ▾ AUTO ▾	Disabled ▾ AUTO ▾	Disabled ▾ AUTO ▾
UART6	<input type="checkbox"/> 115200 ▾	<input type="checkbox"/>	Disabled ▾ AUTO ▾	Disabled ▾ AUTO ▾	Disabled ▾ AUTO ▾

If you are using an external receiver, please do not enable the settings for the Serial Digital Receiver on UART2, as this may conflict with your external receiver, clear your port settings, and prevent the receiver from functioning properly.

DJI O3 Air Unit Solder Connection

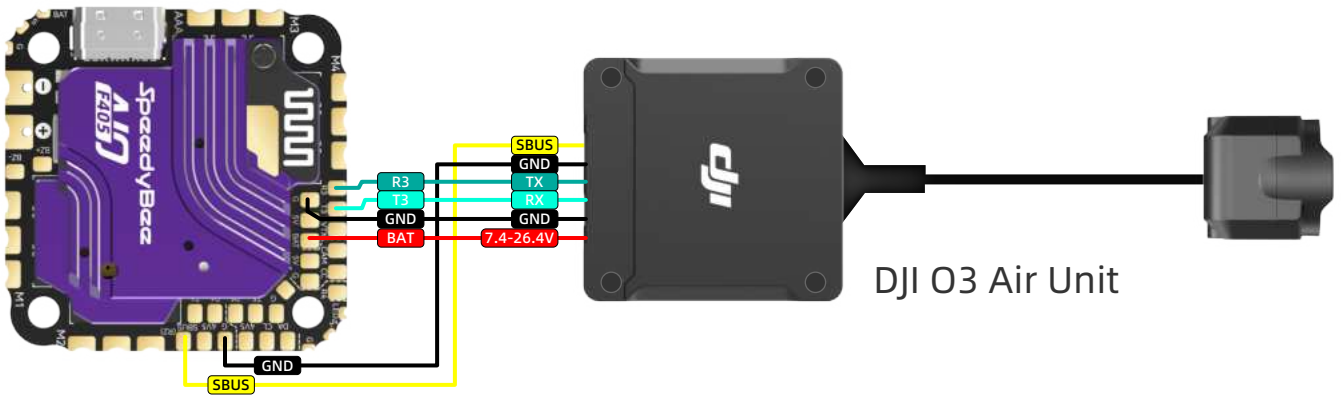

DJI O3 Air Unit Cable Plug Connection

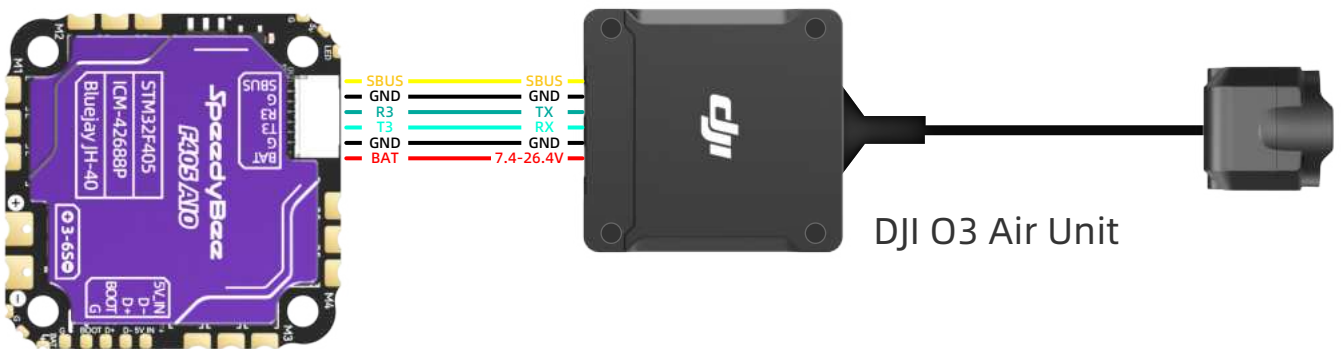

DJI HD VTX Solder Connection

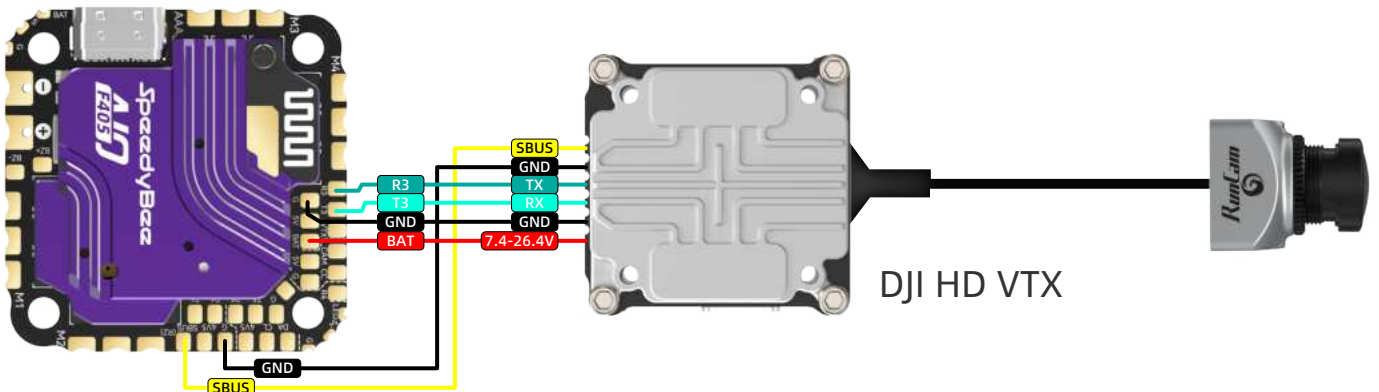

HD VTX Connection and Settings:

DJI HD VTX Cable Plug Connection

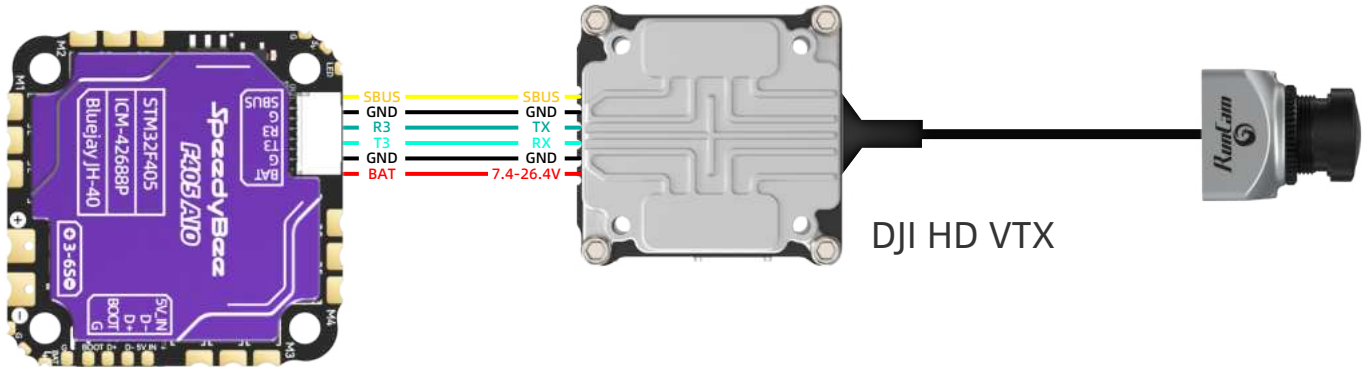

Warning!

The DJI Air Unit only supports 3-4S batteries. Do not connect directly to a 6S battery, as it could damage the DJI Air Unit. Please use the included external BEC and set it to 9V output (by short-circuiting the two pads) before connecting to the DJI Air Unit.

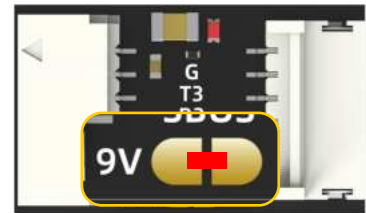

DJI Air Unit Solder Connection

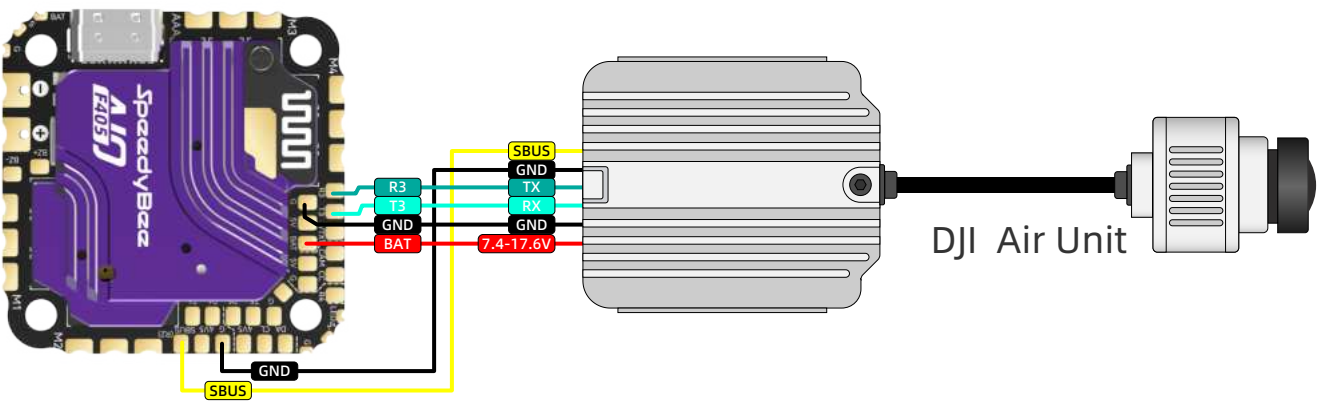

DJI Air Unit Cable Plug Connection

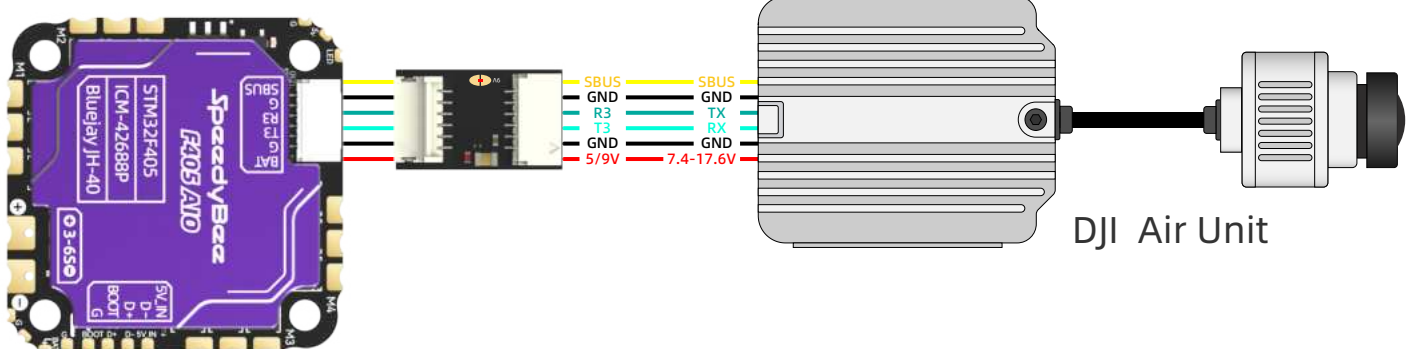

Analog VTX Connection and Settings:

Identifier	Configuration/MSP	Serial Rx	Telemetry Output		Sensor Input		Peripherals	
USB VCP	<input checked="" type="checkbox"/> 115200 ▾	<input type="checkbox"/>	Disabled ▾	AUTO ▾	Disabled ▾	AUTO ▾	Disabled ▾	AUTO ▾
UART1	<input checked="" type="checkbox"/> 115200 ▾	<input type="checkbox"/>	Disabled ▾	AUTO ▾	Disabled ▾	AUTO ▾	Disabled ▾	AUTO ▾
UART2	<input type="checkbox"/> 115200 ▾	<input type="checkbox"/>	Disabled ▾	AUTO ▾	Disabled ▾	AUTO ▾	Disabled ▾	AUTO ▾
UART3	<input type="checkbox"/> 115200 ▾	<input type="checkbox"/>	Disabled ▾	AUTO ▾	Disabled ▾	AUTO ▾	VXT(IRC Tr ▾	AUTO ▾
UART4	<input type="checkbox"/> 115200 ▾	<input type="checkbox"/>	Disabled ▾	AUTO ▾	Disabled ▾	AUTO ▾	Disabled ▾	AUTO ▾
UART5	<input type="checkbox"/> 115200 ▾	<input type="checkbox"/>	Disabled ▾	AUTO ▾	Disabled ▾	AUTO ▾	Disabled ▾	AUTO ▾
UART6	<input type="checkbox"/> 115200 ▾	<input type="checkbox"/>	Disabled ▾	AUTO ▾	Disabled ▾	AUTO ▾	Disabled ▾	AUTO ▾

Note: Leaving CLI tab or pressing Disconnect will **automatically** send "exit" to the board.

With the latest firmware this will make the controller **restart** and unsaved changes will be **lost**.

Warning: Some commands in CLI can result in arbitrary signals being sent on the motor output pins.

This can cause motors to spin up if a battery is connected. Therefore it is highly recommended to make sure that **no battery is connected before entering**

```

Entering CLI Mode, type 'exit' to return, or 'help'
#
#Building AutoComplete Cache ... Done!
#
# set osd_displayport_device = MAX7456
osd_displayport_device set to MAX7456
    
```

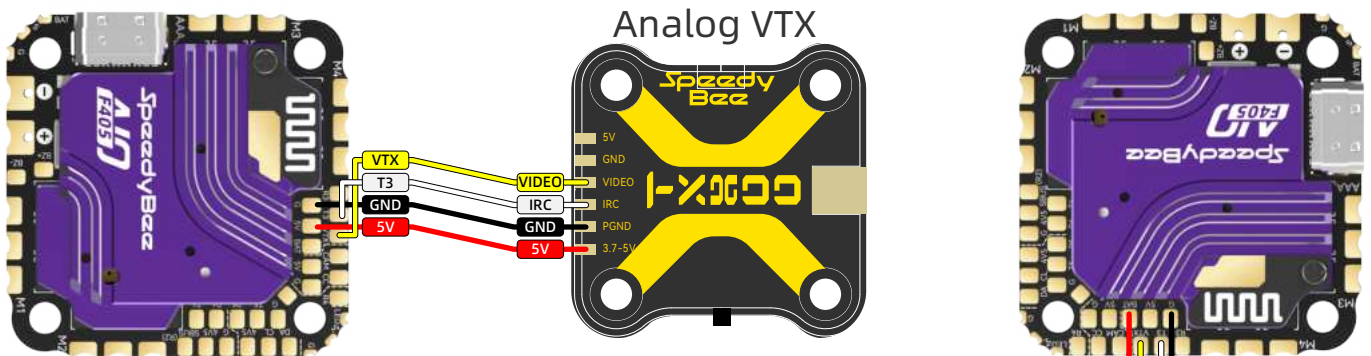

Setting Steps

1. Set UART6 Peripheral to "IRCTramp" and save.
2. In the CLI page, enter the following commands:
set osd_displayport_device = MAX7456
save
3. In the OSD tab, set the video format to PAL or NTSC (depending on the camera protocol).

Active OSD Profile

Current: OSD Profile 1 ▾

Video Format

Auto PAL NTSC HD

Video Format

Auto PAL NTSC HD

Units

Imperial Metric British

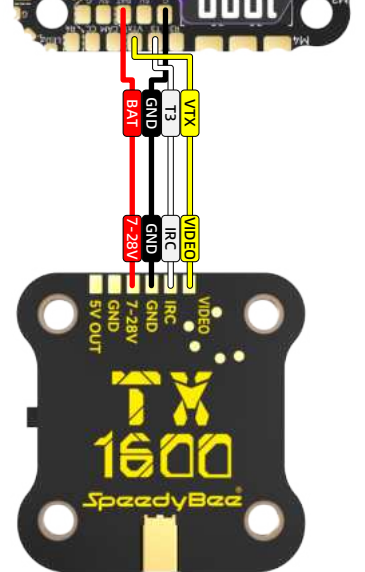

Analog VTX

GPS Connection and Settings:

Identifier	Configuration/MSP	Serial Rx	Telemetry Output	Sensor Input	Peripherals
USB VCP	<input checked="" type="checkbox"/> 115200 ▾	<input type="checkbox"/>	Disabled ▾ AUTO ▾	Disabled ▾ AUTO ▾	Disabled ▾ AUTO ▾
UART1	<input checked="" type="checkbox"/> 115200 ▾	<input type="checkbox"/>	Disabled ▾ AUTO ▾	Disabled ▾ AUTO ▾	Disabled ▾ AUTO ▾
UART2	<input type="checkbox"/> 115200 ▾	<input type="checkbox"/>	Disabled ▾ AUTO ▾	Disabled ▾ AUTO ▾	Disabled ▾ AUTO ▾
UART3	<input type="checkbox"/> 115200 ▾	<input type="checkbox"/>	Disabled ▾ AUTO ▾	Disabled ▾ AUTO ▾	Disabled ▾ AUTO ▾
UART4	<input type="checkbox"/> 115200 ▾	<input type="checkbox"/>	Disabled ▾ AUTO ▾	Disabled ▾ AUTO ▾	Disabled ▾ AUTO ▾
UART5	<input type="checkbox"/> 115200 ▾	<input type="checkbox"/>	Disabled ▾ AUTO ▾	GPS ▾ AUTO ▾	Disabled ▾ AUTO ▾
UART6	<input type="checkbox"/> 115200 ▾	<input type="checkbox"/>	Disabled ▾ AUTO ▾	Disabled ▾ AUTO ▾	Disabled ▾ AUTO ▾

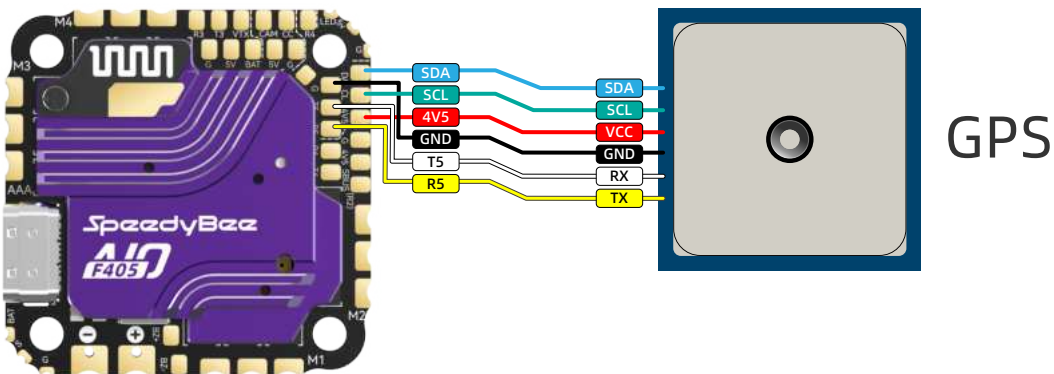

- Setting Steps**
1. Set UART5 Sensor Input to “GPS” on the Ports tab.
 2. Enable GPS on the Configuration tab.
 3. Select protocol based on the GPS used.

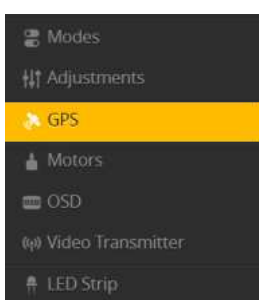
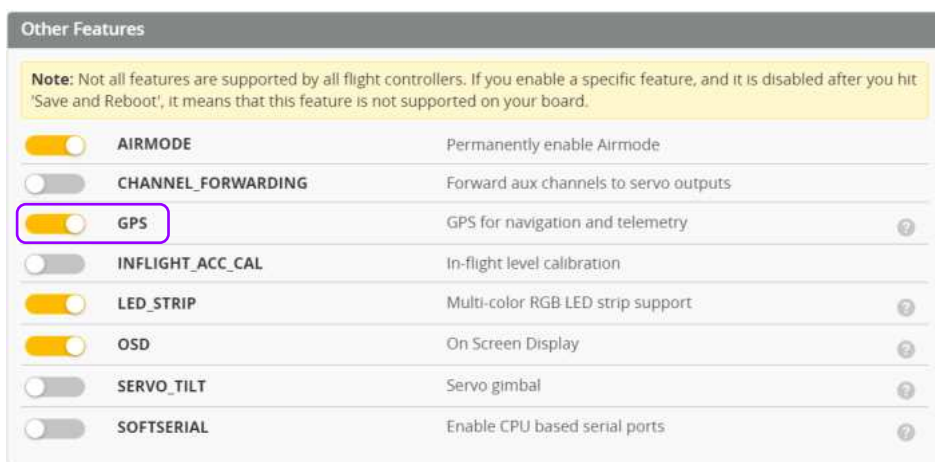
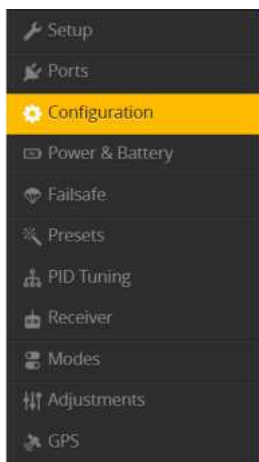

Meteor LED Strip Connection:

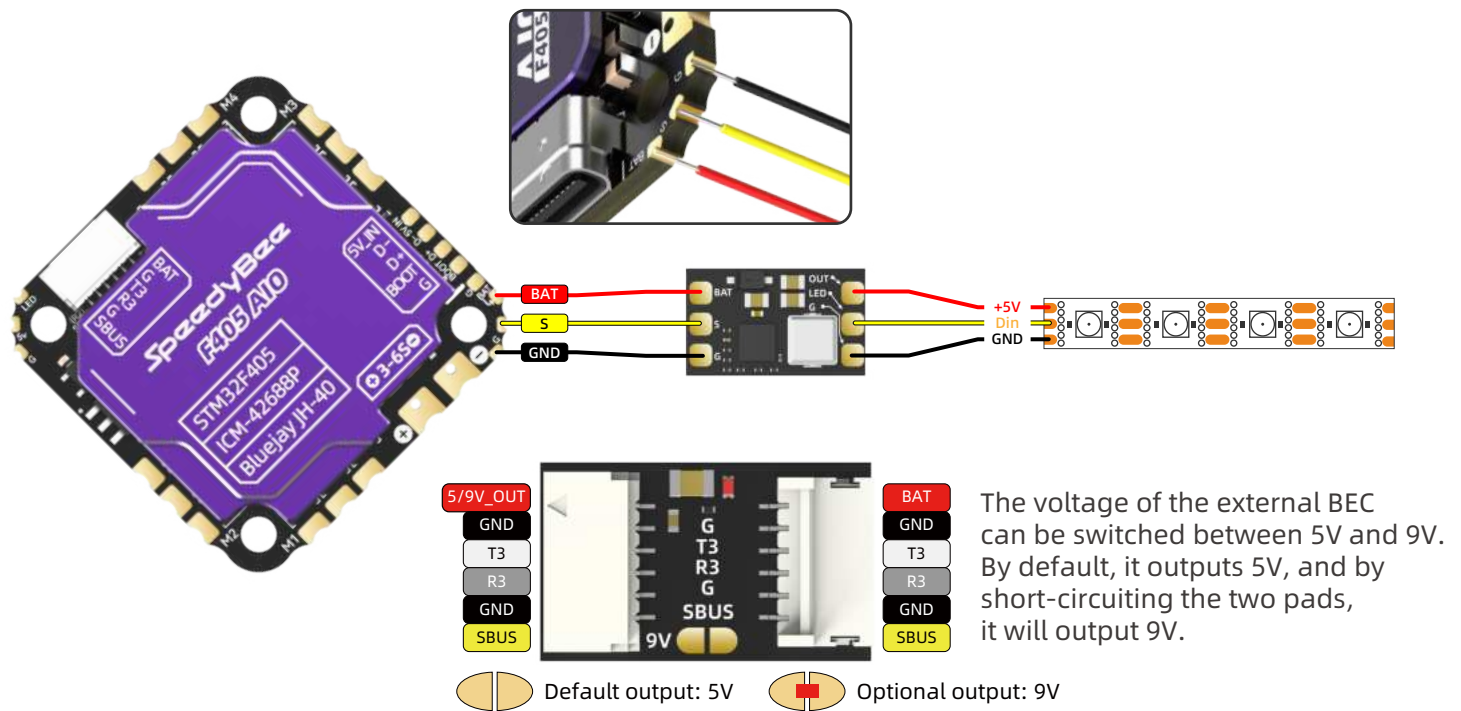

The voltage of the external BEC can be switched between 5V and 9V. By default, it outputs 5V, and by short-circuiting the two pads, it will output 9V.

Meteor LED Function Instructions:

The F405 AIO supports Meteor LED function, allowing multiple LED effects and status indicators. Users can customize the LED effects via the SpeedyBee App.

Operation Steps:

1. Connect to the F405 AIO via the SpeedyBee App.
2. Go to the "Toolbox" at the bottom right corner of the App interface and select "Meteor LED Settings" to start customizing.

Additionally, the F405 AIO supports remote control for the Meteor LED (LED LOW channel needs to be enabled in the mode setting).

Operation Methods:

1. Switch Control:
Set the channel corresponding to the "LED LOW" mode to the high position to turn off the meteor light strip; conversely, setting it to the low position will turn it on.
2. Effect Switching:
Quickly toggle the channel corresponding to the "LED LOW" mode once to switch the Meteor LED effects.

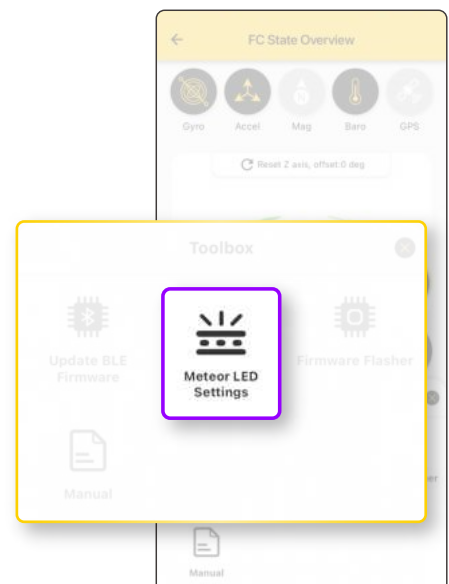
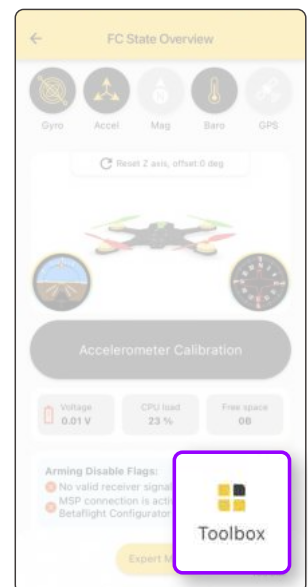

LED Strip Connection:

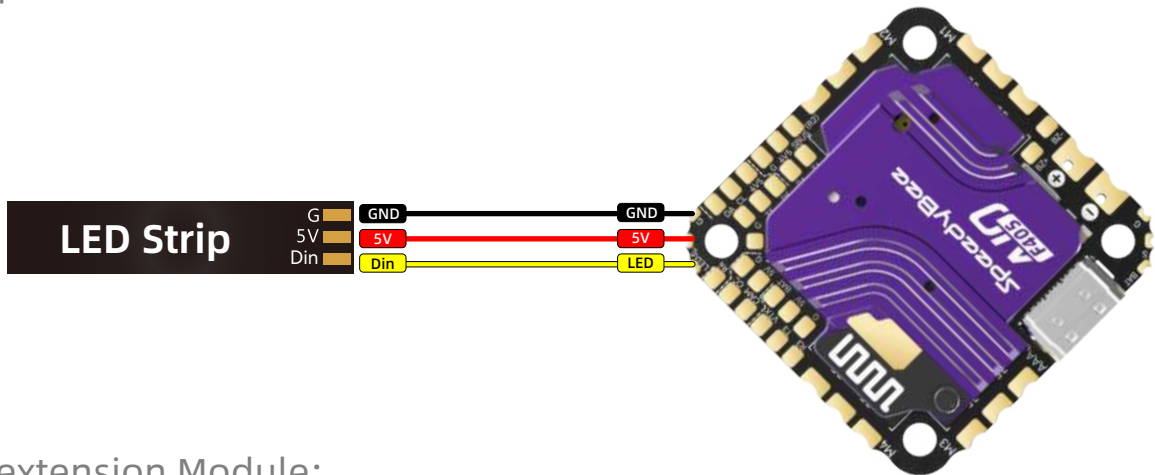

Type-C extension Module:

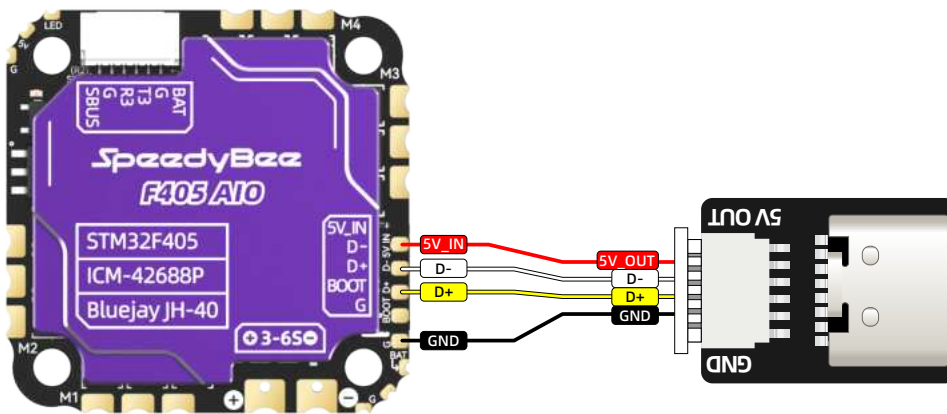

Power Expansion Board:

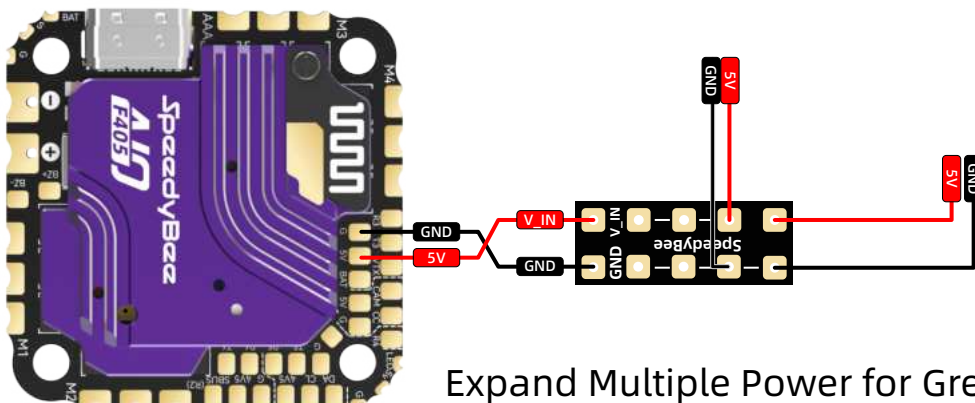

Expand Multiple Power for Greater DIY Flexibility

The power expansion board can convert 1 power source into 4, eliminating the hassle of soldering multiple wires to the same pad and allowing for easy connection of more power devices, such as receivers, LED strips, VTX, GPS, cameras, ect.

1. Install with the front facing up:

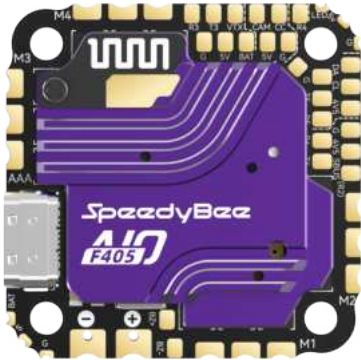

2. Install with the front facing up and rotated 45°counterclockwise:



3. Install with the back facing up:



4. Install with the back facing up and rotated 45°clockwise:

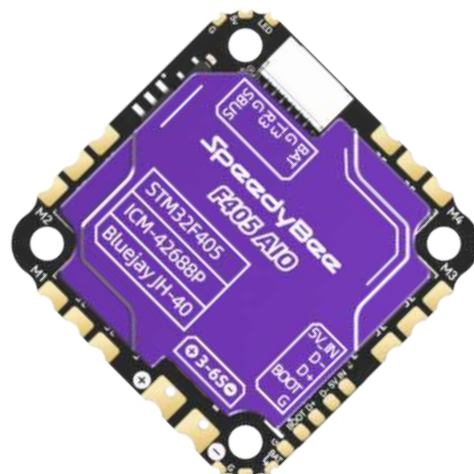

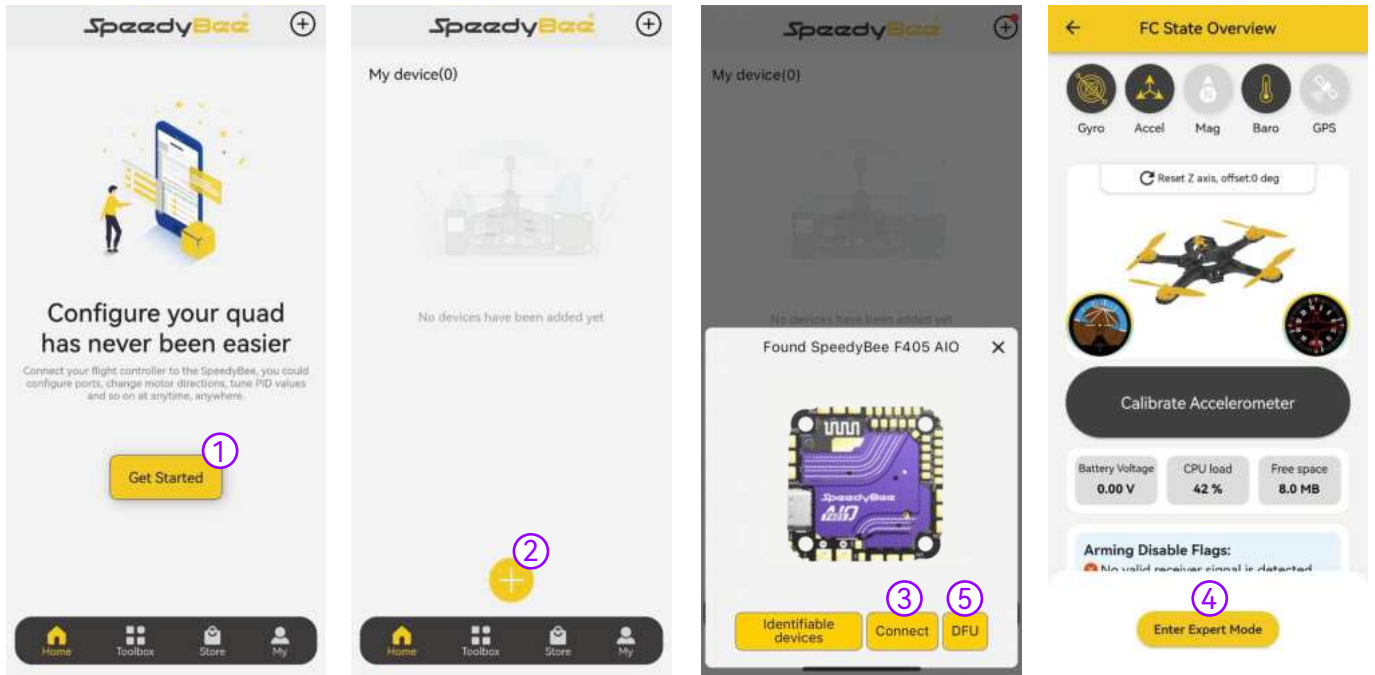

⑤ If it is inconvenient to press the BOOT button during installation, you can use the DFU function via APP to wirelessly trigger the flight controller to enter recovery mode.

How to Use Wireless DFU Function:

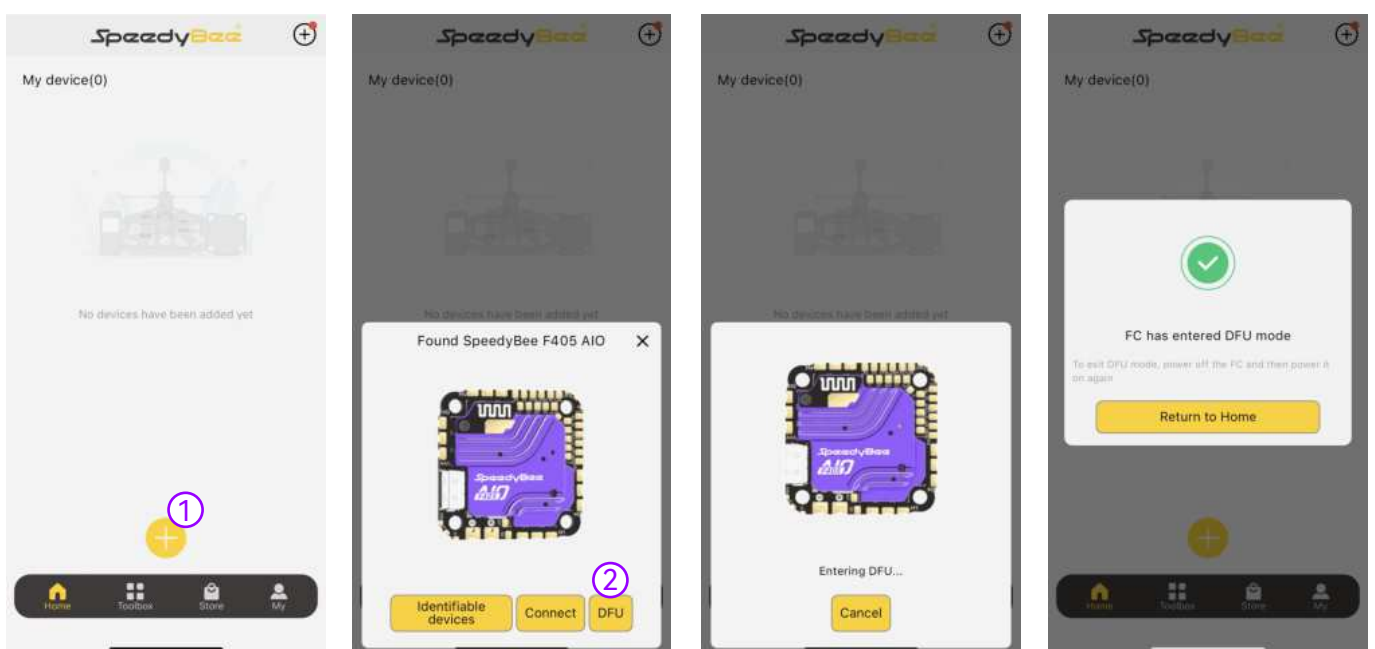

Part 4: Firmware Flashing

► Flashing the Flight Controller Firmware

4.1

1. After entering DFU mode, click the “Update Firmware” button.

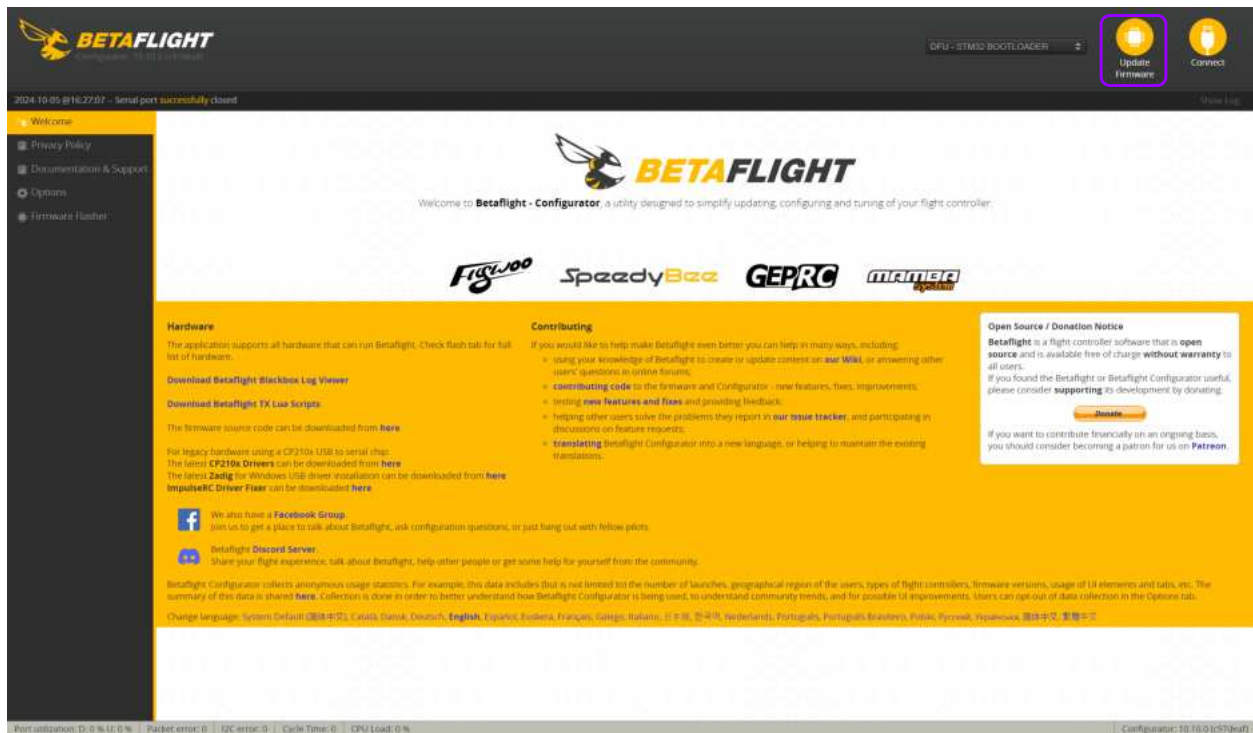

2. Click “Load Firmware (Local)” at the bottom right corner.

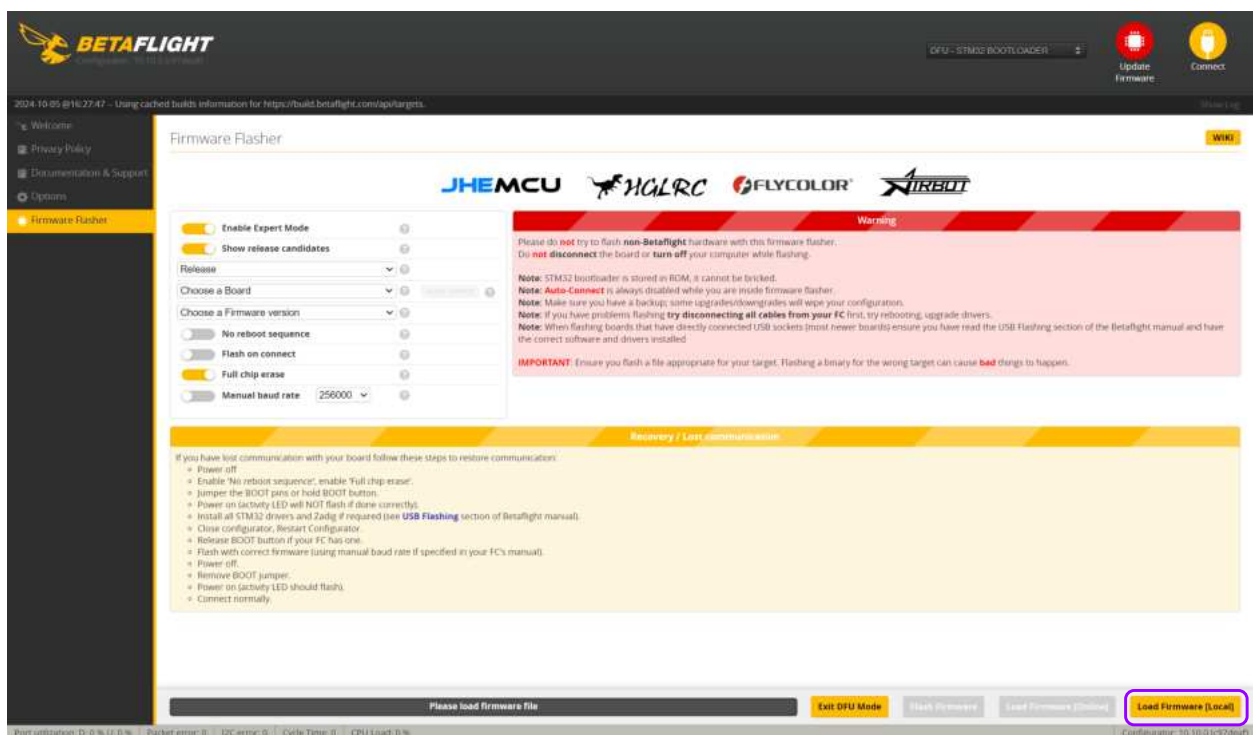

3. Choose the appropriate firmware.

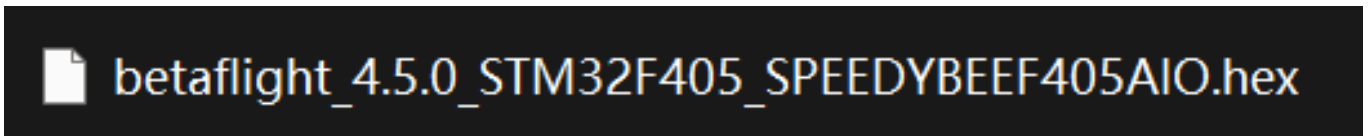

4. Click “Flash Firmware”

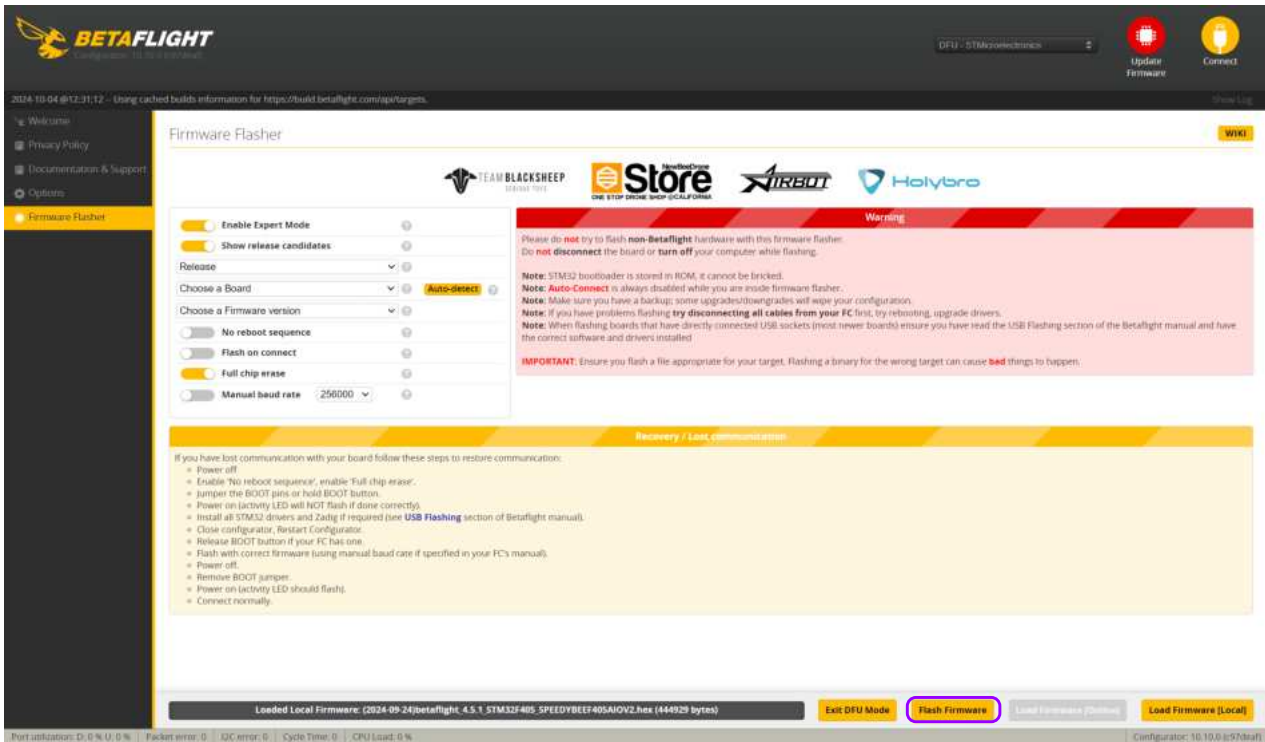

5. Wait until the firmware flashing is complete.

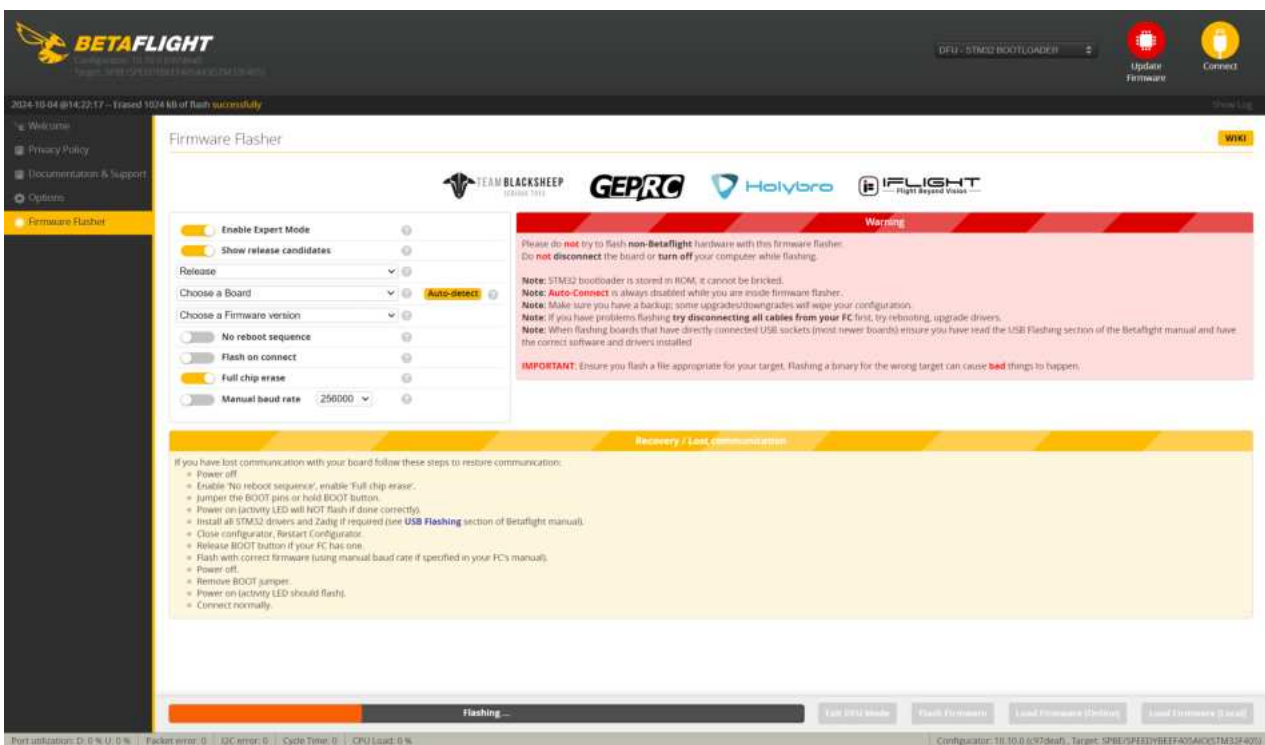

- The ESC supports flashing with either BLHeli_S or BlueJay firmware.

The process is as follows:

1. Power the AIO with a battery.
2. Connect the AIO to the computer via a USB cable.
3. Go to the following link to flash the firmware: <https://esc-configurator.com/>

*Note: Set the ESC type to 'J-H-40'.

esc-configurator.com 想要连接到串行端口

Betaflight STM32F405 (COM4) - 已配对

ESC - Configurator, a utility designed to simplify updating and configuring of your ESCs.

This tool is considered BETA.

Things might not work as expected yet - if you find any bugs please report them. For known browser issues please check the [wiki](#).

Disclaimer

The web application supports ESCs running BLHeli for Atmel, BLHeli for SiLabs and BLHeli_S.

BLHeli FC passthrough is the only interface currently supported.

Should you run into any problems, make sure to use the **Save Debug Log** button and submit a new issue via [GitHub](#).

Application source code can be downloaded from [here](#).

Latest [CP210x Drivers](#) can be downloaded from [here](#).

Latest [STM USB VCP Drivers](#) can be downloaded from [here](#).

Attribution

This project was heavily inspired by the [BLHeli Configurator](#). Most of the UI has been re-written from scratch but a lot of the low level stuff related to flashing and firmware handling have been re-used - so a big shout out to everyone involved in the original BLHeli Configurator.

Attention Bluejay users!

If you are still on 0.20.0, please upgrade to version 0.21.0 - there have been issues with stall detection and motor protection which might result in broken ESCs and/or motors.

This is an experimental web app to configure ESC firmware online.

You will always find the latest stable version here. Currently the following firmware are supported:

- [BLHeli_S](#)
- [Bluejay](#)
- [AM32](#)

BLHeli_S

BLHeli_S probably does not need an introduction - the wildly popular ESC firmware used on almost every EFM8 based ESC in the quadcopter hobby.

Tried and tested, supports every analog and digital protocol out there.

Bluejay

Bluejay is BLHeli_S based firmware capable of bi-directional DShot - so a great choice if you want to run RPM filtering on your rig. This project also aims to clean up and simplify the original BLHeli_S source code.

A startup sound editor is also part of the deal.

Join us on Discord!

If you have any questions or need a quick helping hand, join us on our Discord server:

[Discord](#)

For our Chinese visitors

Tell your friends behind the great firewall of China, that they can reach us via a local [mirror directly in China](#).

Contributing

If you would like to help make ESC Configurator even better you can help in many ways, including:

- Answering other users questions on the forums
- Contributing [code](#) - new features, fixes, improvements
- Submitting [issues](#) with detailed description
- Testing the application on your hardware
- Help [translate](#) the interface into your language

What's next?

If you want to see which features are upcoming, drop by in the [github repository](#). Also feel free to add a feature request if you have an idea that you want to see implemented.

Port utilization: 0.0% U: 0% Packet error: 0 0.32.1

English 11:55:22:336 Settings Open Port Selection Connect

2024-08-21 @ 10:52:36

ESC - Configurator, a utility designed to simplify updating and configuring of your ESCs.

This tool is considered BETA.

Things might not work as expected yet - if you find any bugs please report them. For known browser issues please check the [wiki](#).

Disclaimer

The web application supports ESCs running BLHeli for Atmel, BLHeli for SiLabs and BLHeli_S.

BLHeli FC passthrough is the only interface currently supported.

Should you run into any problems, make sure to use the **Save Debug Log** button and submit a new issue via [GitHub](#).

Application source code can be downloaded from [here](#).

Latest [CP210x Drivers](#) can be downloaded from [here](#).

Latest [STM USB VCP Drivers](#) can be downloaded from [here](#).

Attribution

This project was heavily inspired by the [BLHeli Configurator](#). Most of the UI has been re-written from scratch but a lot of the low level stuff related to flashing and firmware handling have been re-used - so a big shout out to everyone involved in the original BLHeli Configurator.

Attention Bluejay users!

If you are still on 0.20.0, please upgrade to version 0.21.0 - there have been issues with stall detection and motor protection which might result in broken ESCs and/or motors.

This is an experimental web app to configure ESC firmware online.

You will always find the latest stable version here. Currently the following firmware are supported:

- [BLHeli_S](#)
- [Bluejay](#)
- [AM32](#)

BLHeli_S

BLHeli_S probably does not need an introduction - the wildly popular ESC firmware used on almost every EFM8 based ESC in the quadcopter hobby.

Tried and tested, supports every analog and digital protocol out there.

Bluejay

Bluejay is BLHeli_S based firmware capable of bi-directional DShot - so a great choice if you want to run RPM filtering on your rig. This project also aims to clean up and simplify the original BLHeli_S source code.

A startup sound editor is also part of the deal.

Join us on Discord!

If you have any questions or need a quick helping hand, join us on our Discord server:

[Discord](#)

For our Chinese visitors

Tell your friends behind the great firewall of China, that they can reach us via a local [mirror directly in China](#).

Contributing

If you would like to help make ESC Configurator even better you can help in many ways, including:

- Answering other users questions on the forums
- Contributing [code](#) - new features, fixes, improvements
- Submitting [issues](#) with detailed description
- Testing the application on your hardware
- Help [translate](#) the interface into your language

What's next?

If you want to see which features are upcoming, drop by in the [github repository](#). Also feel free to add a feature request if you have an idea that you want to see implemented.

Port utilization: 0.0% U: 0% Packet error: 0 0.32.1

Warning: Turn off your radio! Otherwise flashing might fail, especially on highly integrated AIOs.

Note: Make sure you've taken the propellers OFF before doing anything on this tab.
Note: Connect power to the ESCs.

Motor Control

Make sure your ESCs are properly set up to reflect the state of the sliders.
Eg: When you enabled 3D mode in your flight controller, make sure the ESCs are also set up for 3D mode, otherwise the motors might go off with full power.

Also be aware that the motors will not spin if you have bi-directional Dshot enabled on the Flight-controller, but the ESC does not support it. Which might be the case when flashing from RPM enabled firmware to BLHeli_S.

Enable motor control Battery: 6S @ 24.32V

Motor 1 Master Speed

1000 1000

Motor 2

1000

Motor 3

1000

Motor 4

1000

Save Debug Log Clear Debug Log Restore Default Settings Flash All ESCs Write Settings Read Settings

Port utilization: 0.0% U: 0% Packet error: 0 0.32.1

2024-08-21 @ 10:54:51 -- Done reading ESCs

Warning: Turn off your radio! Otherwise flashing might fail, especially on highly integrated AIOs.

Note: Make sure you've taken the propellers **OFF** before doing anything on this tab.
Note: Connect power to the ESCs.

Common Parameters

- Minimum Startup Power (Boost): 1025
- Maximum Startup Power (Protection): 1100
- Motor Timing: 22.5° (Medium-high)
- Demag Compensation: Low
- RPM Power Protection (Rampup): 0x

Beacon Settings

- Beep Strength: 40
- Beacon Strength: 80
- Beacon Delay: 10 minutes

Safety Settings

- ESC Power Rating: 25+
- Temperature Protection: 140 C

Brake Settings

- Brake on stop:
- Maximum Braking Strength: 255

Experimental Settings

Save Debug Log | Clear Debug Log

ESC 1: J-H-40 - Bluejay, 0.19, 48kHz
 Normal | Motor Direction
 Off | LED Configuration
 Flash Firmware to this ESC

ESC 2: J-H-40 - Bluejay, 0.19, 48kHz
 Normal | Motor Direction
 Off | LED Configuration
 Flash Firmware to this ESC

ESC 3: J-H-40 - Bluejay, 0.19, 48kHz
 Reversed | Motor Direction
 Off | LED Configuration
 Flash Firmware to this ESC

ESC 4: J-H-40 - Bluejay, 0.19, 48kHz
 Normal | Motor Direction
 Off | LED Configuration
 Flash Firmware to this ESC

Open Melody Editor | Restore Default Settings | **Flash All ESCs** | Write Settings | Read Settings

Port utilization: 0.0% I: 0% Packet error: 0 0.32.1

2024-08-21 @ 10:51:17 -- ESC 读取完成

Ignore inappropriate MCU and Layout? (Flashing inappropriate firmware may damage your ESC, do so at your own risk)

Migrate settings between different firmwares? (This will attempt to migrate settings between different firmwares like for example from BLHLE_S to Bluejay)

Note: Be aware that settings are not migrated between different firmwares, make sure to take note of your motor directions and other settings, you might want to move over. Settings will be migrated between different versions of the same firmware.

Select Target (J-H-40 - Bluejay, 0.19, 48kHz)

Bluejay | Firmware
 J-H-40 | ESC
 v0.19.2 | Version

Attention!
 When flashing new (or different) ESC firmware it is best practice to adhere to the following checklist:

- Read the release notes to understand what changed and what you might need to adjust
- Make sure your motors spin up reliably on arm and in the correct direction
- Check motor temperatures after a short test flight and adjust tune if they are too hot

Show release notes on Github

Flash
 Flash Local Firmware
 Cancel

Port utilization: 0.0% I: 0% Packet error: 0 0.32.1

Flight Controller

Product Name	SpeedyBee F405 AIO
MCU	STM32F405
Gyro	ICM-42688P
USB Port Type	Type-C
Barometer	SPA06-003
OSD	Supported
Bluetooth BLE	Supported, Bluetooth speed enhancement - 2.0
Wireless Flight Controller Firmware Update	Supported (no need to press physical BOOT button)
Wireless Download & Black Box Analysis	Not supported
DJI Air Unit Connection Method	Supports both 6-pin direct insertion and soldering
6-pin DJI Sky Port Direct Insertion	Supported, can directly connect to DJI O3/RunCam Link /Caddx Vista without changing wire order
Flash (for BlackBox)	8MB
Betaflight CC Pads (Camera Parameter Adjustment)	Supported
Input Voltage	3S-6S LiPo battery
4V5 Output	Two 4V5 outputs; total current 1A
5V BEC Output	Three 5V outputs; total current 2A; shared with 4V5
9V BEC Output	None (comes with an external BEC module, can switch between 5V and 9V); total current output 2A
MOTOR	M1-M4
UART	4 full-function serial ports (UART3,UART4,UART5,UART6+SBUS[R2])
ESC Telemetry	None
I2C	Supported
LED Pads	Supported, used to control WS2812 LED lights
Buzzer Pads	Supported, BZ+ and BZ- pads
BOOT Button	Supported, press and hold the BOOT button while powering on to enter DFU mode for firmware recovery
RSSI Pads	None
SmartPort	Not supported

Flight Controller

Supported Flight Controller Firmware	BetaFlight(Default), INAV
Firmware Target Name	SPEEDYBEE F405AIO
Mounting	25.5 x 25.5mm, 2mm hole diameter
Dimensions	33.0mm (length) x 33.0mm (width) x 8mm (height)
Weight	13.6g (including CNC)

ESC

Product Name	SpeedyBee F405 AIO
Input Voltage	3-6S LiPo battery
Continuous Current	40A
Burst Current	45A (10s)
ESC Protocol	Supports DSHOT600/300; other protocols may cause severe errors, please use with caution.
Output Voltage	VBAT battery voltage (used to power the flight controller)
Current Sensor	Supported (Scale = 254, Offset = 0)
Firmware	Bluejay JH-40 48kHz